

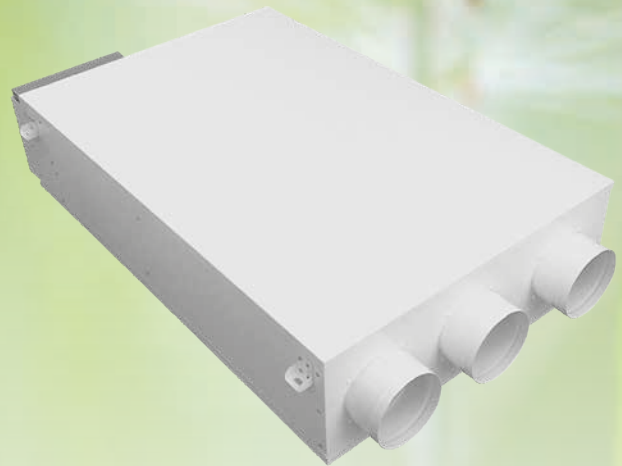

EOS B EC

INTEGRATED
RECOVERY
UNIT,
WATER BASED



SOMETHING DIFFERENT

EOS B **GB**

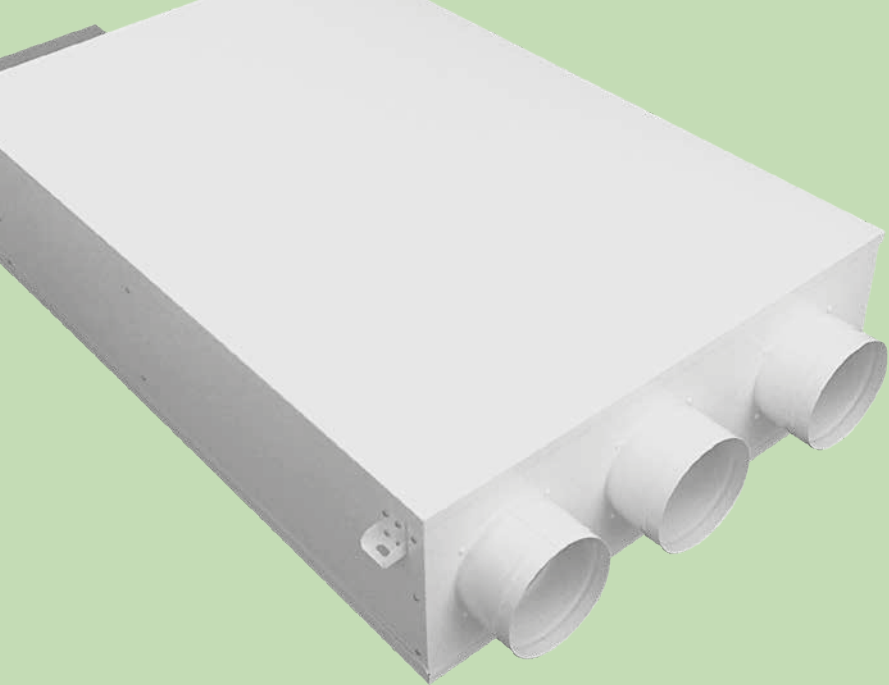

EOS B EC

A RECOVERY UNIT
INTEGRATED,
WATER BASED

BREATHE IN WELLNESS AND BOOST YOUR ENERGY

We spend most of our days indoors, in increasingly "air-tight" environments.

To create a healthy and comfortable environment it is essential that there is sufficient air exchange, which lowers the percentage of CO2 and relative humidity inside a room and avoids mould growth.

To avoid uncontrolled ventilation and allow energy saving, we have created the new EoS B - a complete air conditioning system developed for the well-being and comfort of air.

ADVANTAGES

- Better air quality: it removes spent air from the bathroom and kitchen where the concentration of pollutants and humidity is highest and prevents it from flowing out into the rooms.
- Energy efficiency at lower cost: the fresh air taken from the outside is pre-treated, filtered, and integrated (dehumidified) to bring the rooms to comfort conditions.
- Reduced exposure to external noise and atmospheric pollution: it is no longer necessary to open the windows to ensure air exchange.
- Flexibility: it is compact and easy to install, an excellent solution also for renovations.
- Advanced adjustment: maximises system performance and therefore energy saving while reaching the desired comfort conditions.

COMPACT SIZE

A SINGLE SYSTEM WITH COMPACT DIMENSIONS ABLE TO ENSURE AND MANAGE THE DESIRED INDOOR COMFORT CONDITIONS:

- RENEW AND FILTER AIR
- COOL AND DEHUMIDIFY
- HEAT
- MANAGEMENT OF MULTIZONE COMFORT, ALSO VIA AN APP

IDEAL FOR EFFICIENT BUILDINGS - NEW OR TO BE RENOVATED.

HIGH PERFORMANCE AND ENERGY SAVING

HEAT RECOVERY UNIT SUPPLIED WITH THE HIGH EFFICIENCY EOS UNITS, COUNTER-FLOW SYSTEM.

THANKS TO 90%-PLUS EFFICIENCY, IT IS POSSIBLE TO SAVE ENERGY AND THEREFORE, MONEY. EOS COMPLIES WITH THE ERP "ECODESIGN" DIRECTIVE.

IDEAL COMFORT

THE TREATED AIR IS FED TO THE ROOMS, IN THE RIGHT AMOUNT, THANKS TO THE INNOVATIVE VARIABLE AIR VOLUME SYSTEM.

IN THIS WAY THE USE OF ENERGY IS OPTIMISED, MINIMISING CONSUMPTION AND GUARANTEEING TOP PERFORMANCE, IN TERMS OF THERMO-HYGROMETRIC COMFORT, VENTILATION AND LOW NOISE.

FREE-COOLING

IN MIDDLE SEASONS, THANKS TO THE OPENING OF THE MOTORIZED BY-PASS VALVE, IT AUTOMATICALLY ALLOWS THE INTAKE OF OUTDOOR AIR AND ITS FEEDING TO THE INDOOR ENVIRONMENTS, HEATING OR COOLING AT NO OTHER COST THAN THE FANS' POWER SUPPLY.

LOW-NOISE

LATEST GENERATION EC FANS ARE AMONG THE LOWEST-NOISE PRODUCTS ON THE MARKET.

THANKS TO THEIR ADVANCED CONTROL SYSTEM, IN COMBINATION WITH A WELL DESIGNED AND INSULATED DISTRIBUTION SYSTEM AND OPERATING LOGIC OF THE VENTILATION SYSTEM, EXTREMELY LOW SOUND EMISSION LP <30 DB (A) CAN BE GUARANTEED.



COOLING

3.2/6.3_{kw}



HEATING

4/8_{kw}



AIR FLOW

500-1000_{m³/h}



REDUCTION IN CONSUMPTION

60%



OPTIONS

- REMOTE MANAGEMENT APP
- HUMIDITY SENSOR
- AIR QUALITY SENSOR
- SINGLE-ZONE PLENUM
- MULTI-ZONE PLENUM
- SANITIZED FILTER
- ELECTROSTATIC FILTER
- SANIFAN DEVICE
- CAN BE COMBINED WITH OTHER HYDRONIC TERMINALS
- POSSIBLE MANAGEMENT BY BMS

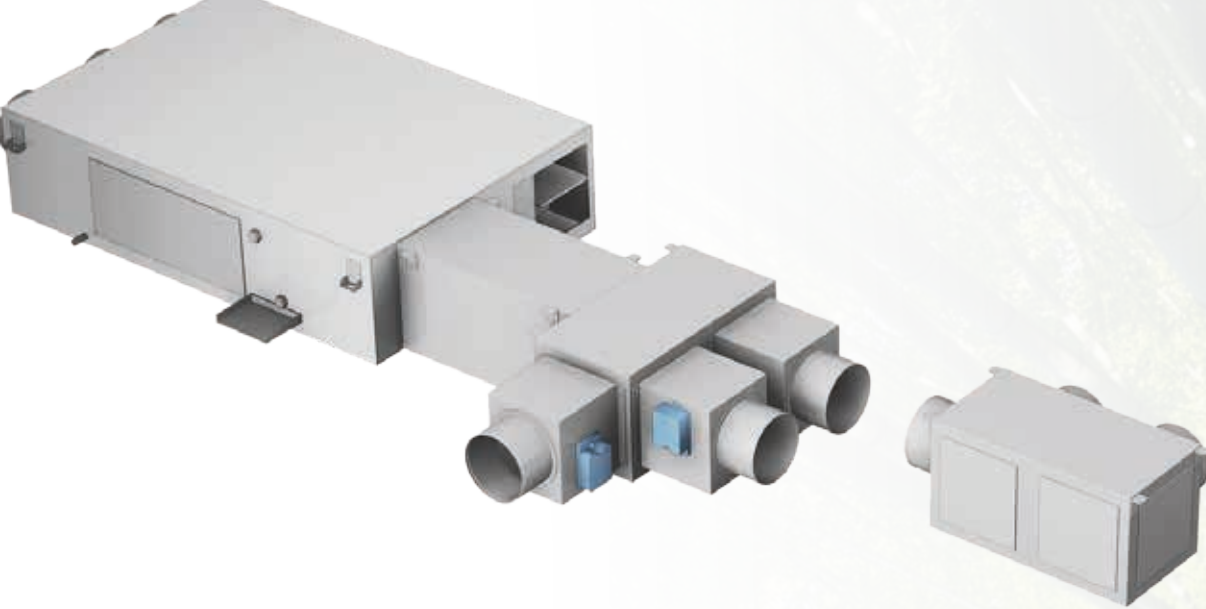

SOLUTIONS

Aertesi proposes a system consisting of two separate elements: an indoor unit, designed to exchange heat with the internal environment, and an outdoor unit that exchanges heat with the outside.

Having two separate units avoids sources of noise inside the premises and is an ideal system engineering solution to make the most of the available living space.

W
WATER
TO FEED WITH
HYDRONIC HEAT
PUMP

H HORIZONTAL
VERSION

V VERTICAL
VERSION

FLOW RATE FOR AIR RENEWAL



EOSB 3
cu.m/h 200

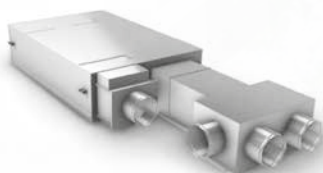

EOSB 6
cu.m/h 400

MODEL IDENTIFICATION

EOSB1	3	H	W
MODEL	SIZE	VERSION	CONFIGURATION

MODEL SELECTION GUIDE:

**EOS B 3 FOR RENEWAL SUITABLE
FOR 150m²**

**EOS B 6 FOR RENEWAL SUITABLE
FOR APPROX. 300m²**

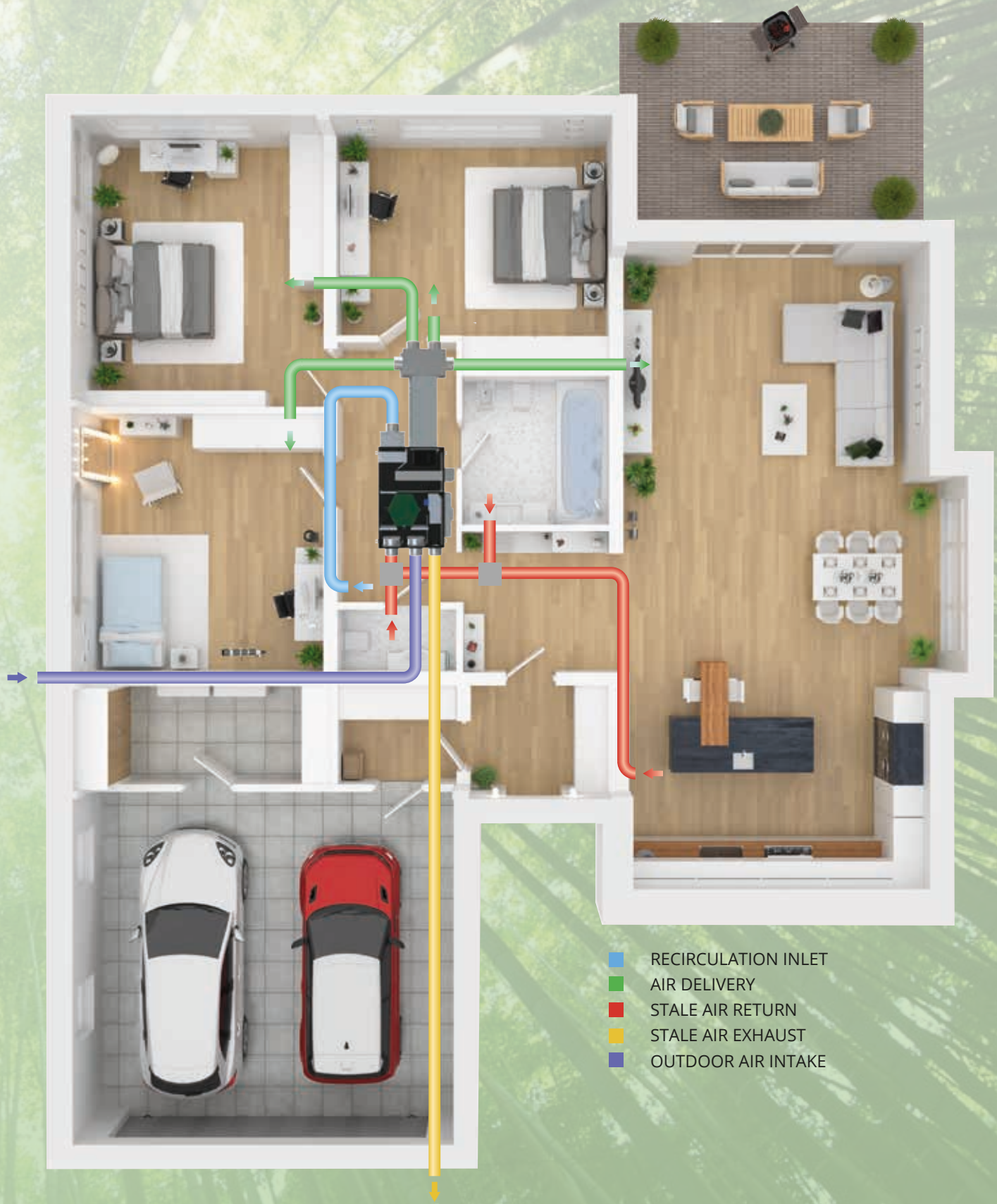

- RECIRCULATION INLET
- AIR DELIVERY
- STALE AIR RETURN
- STALE AIR EXHAUST
- OUTDOOR AIR INTAKE



HIGH EFFICIENCY RECOVERY UNIT

Made of polyester with solvent-free elastic adhesives, it works with outdoor air temperatures between -30 and +50° C with up to 90% energy recovery.

A special anti-freeze cycle has been implemented in the units to prevent the formation of ice and any damage to the exchanger.

The heat transferred from the return air to the fresh renewal air helps to keep the temperature above freezing point, even when the outdoor air is very cold. Below -5°C preheating at air inlet is required.

ADJUSTMENT

The EOS B series features a "self-adaptable" electronic adjustment system to control:

- Air flow rates (variable rpm fans)
 - Temperature (air delivery and room temperatures)
 - Humidity (environment)
 - Recirculation (environment)
 - Air filtration
- Free-cooling management

These features make this system unique in terms of flexible comfort management.

COMPONENTS AND ACCESSORIES

LOAD-BEARING STRUCTURE

in galvanised steel 1.00 mm

INSULATING

soundproofing and thermal insulation with cross-linked, 10 mm thick, fire reaction class 1 polythene.

AIR RENEWAL-EXHAUST FANS

backward curved blades with directly coupled, low consumption EC motor.
Recirculation fan: forward curved blades with directly coupled, low consumption EC motor.

HEAT EXCHANGER

consisting of copper pipes and corrugated aluminium fins to maximise heat exchange; with collar to optimise thermal conduction. Equipped with a stainless steel condensate collection tray.

HEAT RECOVERY UNIT

in highly efficient counter-current cross-flow polystyrene with stainless steel condensate collection tray. Compared to aluminium exchangers, it features higher efficiency because it does not conduct heat in the direction of the air flow.

FREE-COOLING DAMPER

motorised damper with low voltage servomotor, controlled by the regulator according to the outdoor and indoor temperature. (Supplied separately)

ON REQUEST, THE FOLLOWING ACCESSORIES CAN BE SUPPLIED:

**DISTRIBUTION PLENUM
MULTIZONE WITH DAMPERS
DISTRIBUTION PLENUM
SINGLE ZONE (WITHOUT DAMPERS)
AMBIENT HUMIDITY SENSOR
ELECTROSTATIC FILTERS
BMS CONNECTION
HUMIDIFIER
CO2 SENSOR
ELECTRICAL HEATER
DELIVERY SILENCER**



USER CONSOLE

SUPPLIED WITH BASIC EOS.
WORKS INDEPENDENTLY FOR SINGLE-ZONE CONFIGURATION OR FROM A CENTRAL WORKSTATION FOR SINGLE-ZONE CONFIGURATION.



TEMPERATURE/HUMIDITY SENSOR

SINGLE-ZONE OR MULTI-ZONE

THE SENSOR ALLOWS SUMMER DEHUMIDIFICATION FUNCTION ENABLING. THE ADJUSTMENT ALLOWS UP TO 6 SENSORS TO BE USED, CONNECTED TO THE SAME UNIT.



CO2 SENSOR

THE SENSOR ALLOWS AIR RENEWAL TO BE MANAGED ACCORDING TO THE ACTUAL CO2 LEVEL IN THE ROOM. THE ADJUSTMENT ALLOWS UP TO 4 SENSORS TO BE USED, CONNECTED TO THE SAME UNIT.

OPERATING PRINCIPLE

RECIRCULATION

ACTIVE WATER COIL

The air taken from the room is chilled, dehumidified (in summer) or heated (in winter) and delivered back to the room. Air treatment is carried out using the outdoor heat pump unit. In summer, by activating the dehumidification function, the treated air flow is kept to a minimum, so that air is dehumidified with only a small appreciable cooling fraction.



STALE AIR EXHAUST

OUTDOOR AIR INTAKE

STALE AIR INTAKE FROM TOILET OR KITCHEN

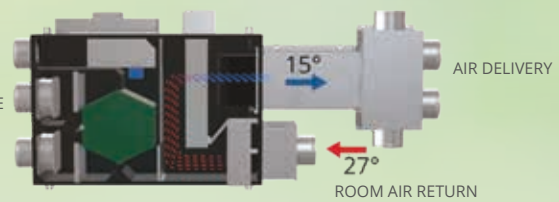

BOTTOM VIEW



STALE AIR EXHAUST

OUTDOOR AIR INTAKE

STALE AIR INTAKE FROM TOILET OR KITCHEN

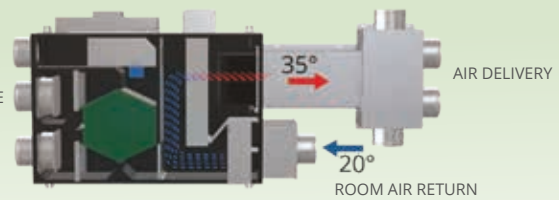

BOTTOM VIEW

RENEWAL WITH RECOVERY

WATER COIL NOT ACTIVE AND VENTILATION ONLY

The stale air is fed through the cross-flow recovery unit, in which its thermal (in winter) or cooling (in summer) power is transferred to the fresh renewal air taken from outdoors. Thanks to the high efficiency of the heat recovery unit, the fresh renewal air is delivered to the rooms at a temperature very close to the ambient temperature.

In this operating mode the coil is not active so the only energy expenditure is the amount necessary for indoor ventilation.



AIR DELIVERY

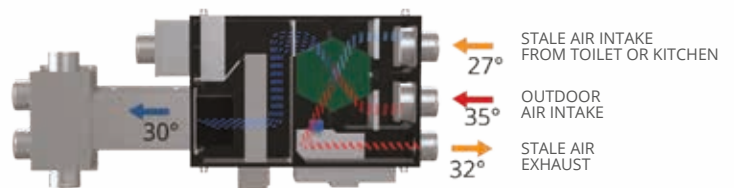

BOTTOM VIEW



AIR DELIVERY

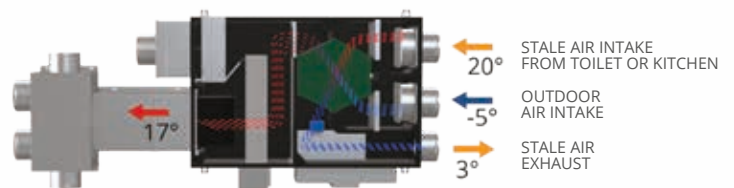

BOTTOM VIEW

FREE-COOLING RECIRCULATION

WATER COIL NOT ACTIVE AND VENTILATION ONLY

If the control is set on cooling mode, when the outdoor temperature is lower than the indoor temperature, the unit regulator will open the free-cooling damper. In this way, the heat recovery unit is bypassed and chilled air is delivered to the environment, using up only the amount of electrical energy necessary for ventilation, since the water coil is not active.

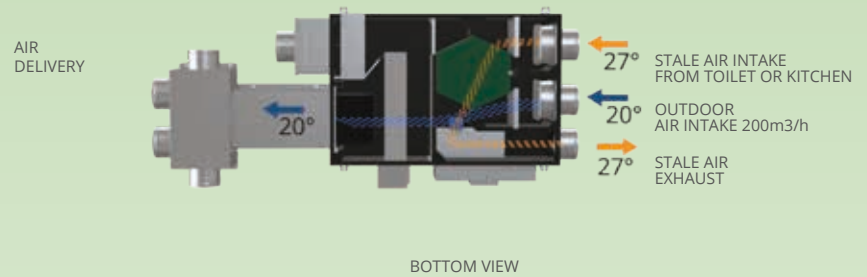

RECIRCULATION WITH RENEWAL

ACTIVE WATER COIL

The stale air is fed through the cross-flow recovery unit, in which its thermal (in winter) or cooling (in summer) power is transferred to the fresh renewal air taken from outdoors. Thanks to the high efficiency of the heat recovery unit, the fresh renewal air is mixed with recirculation air at a temperature very close to the ambient temperature. Before being released into the room, air is heated or cooled by the direct expansion coil. Thanks to the cross-flow heat recovery unit, which pre-heats (in winter) or pre-cools (in summer) the fresh air using the exhausted air, the heating or cooling capacity required from the heat pump is considerably reduced.

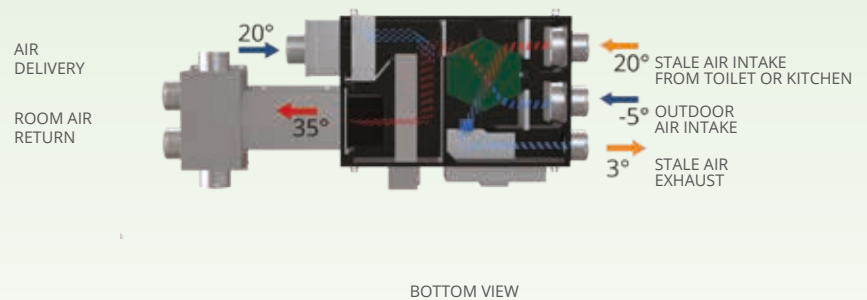
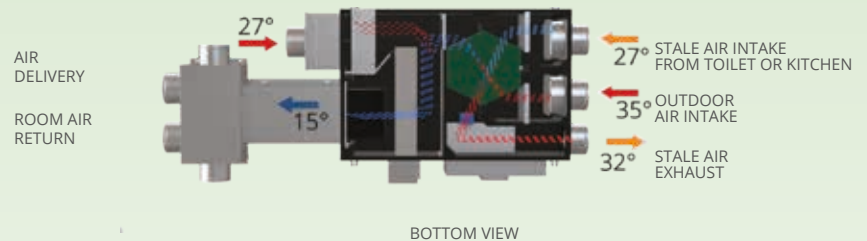

DIMENSIONS

SIZE	HORIZONTAL				VERTICAL			
	A	B	C	WEIGHT	A	B	C	WEIGHT
3	1325	275	835	50	760	1300	350	55
6	1550	445	985	65	910	1440	500	70

A = length mm
B = height mm
C = depth mm

EOS B 3 HORIZONTAL

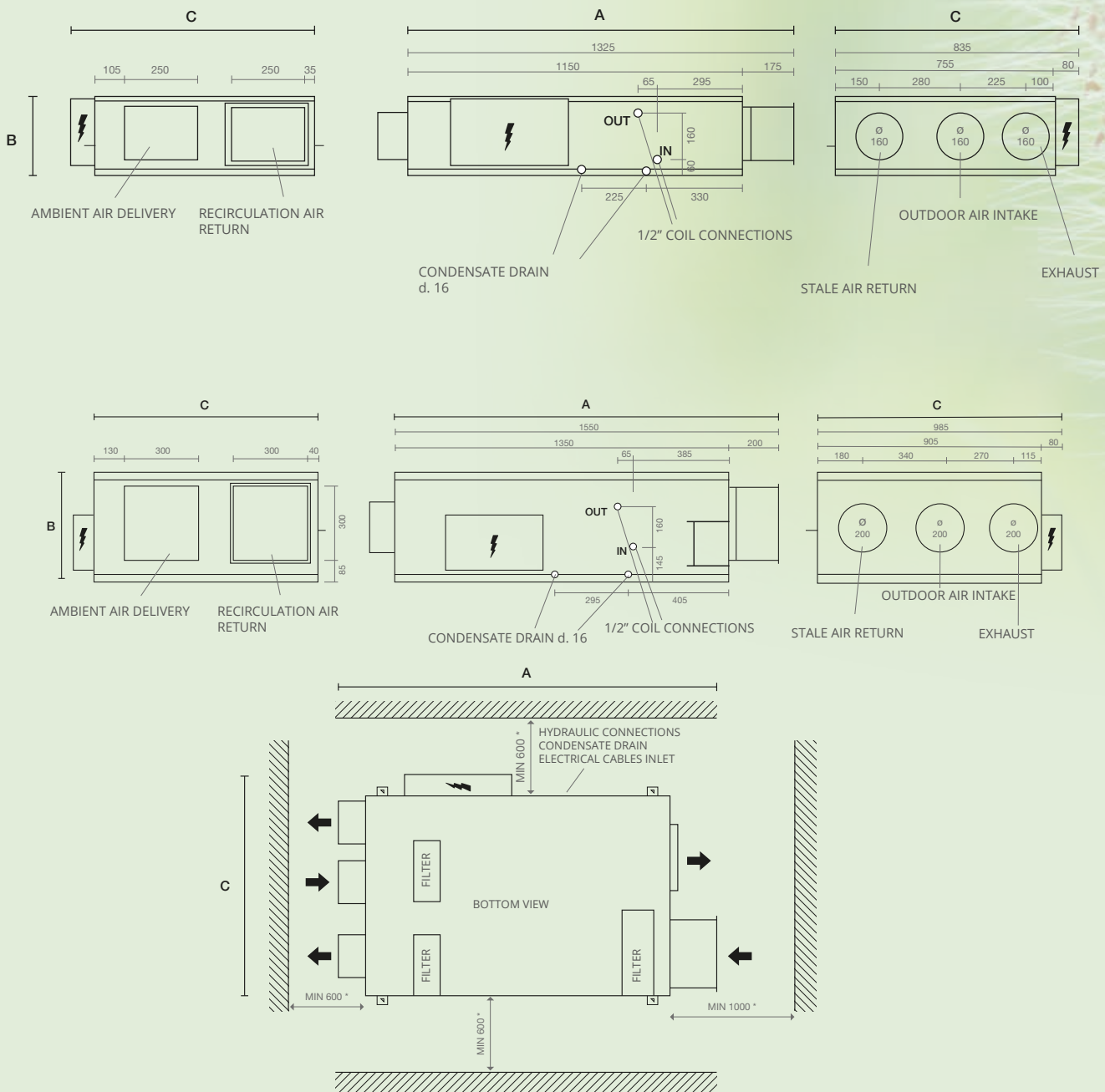

EOS B 3

VERTICAL

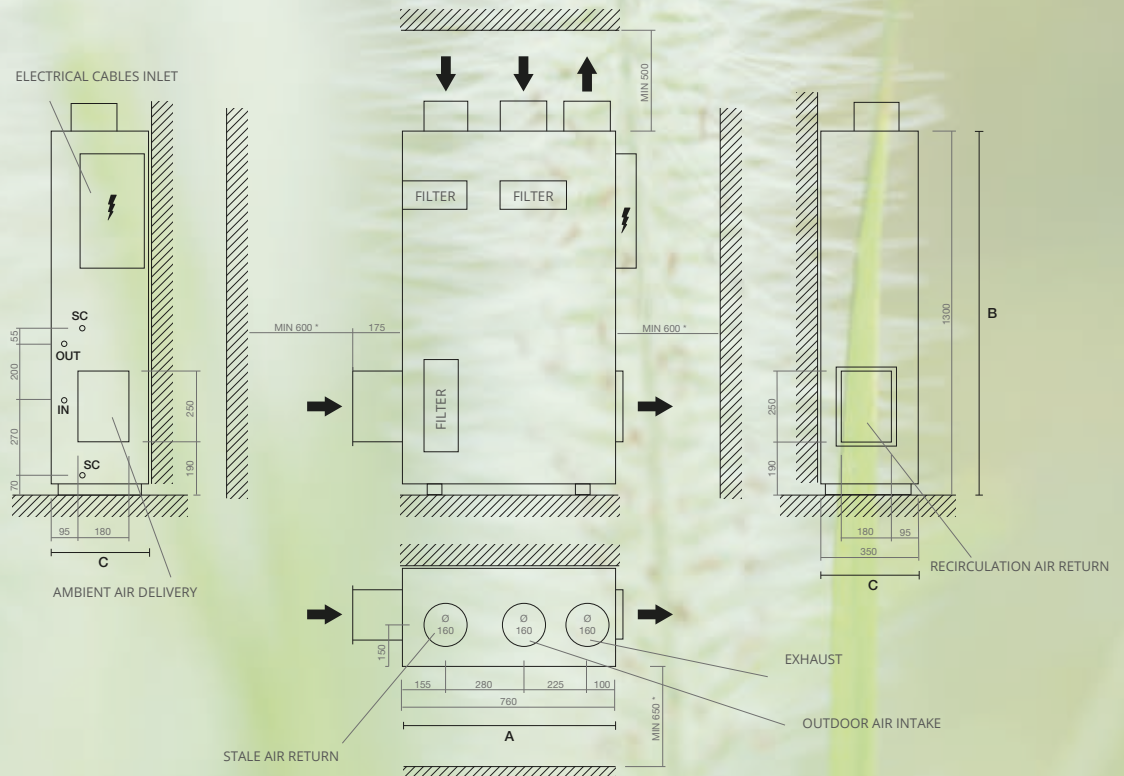

*MINIMUM CLEARANCE VALUES TO OBSERVE FOR MAINTENANCE OF A PRE-INSTALLED WORKING MACHINE

EOS B 6

VERTICAL

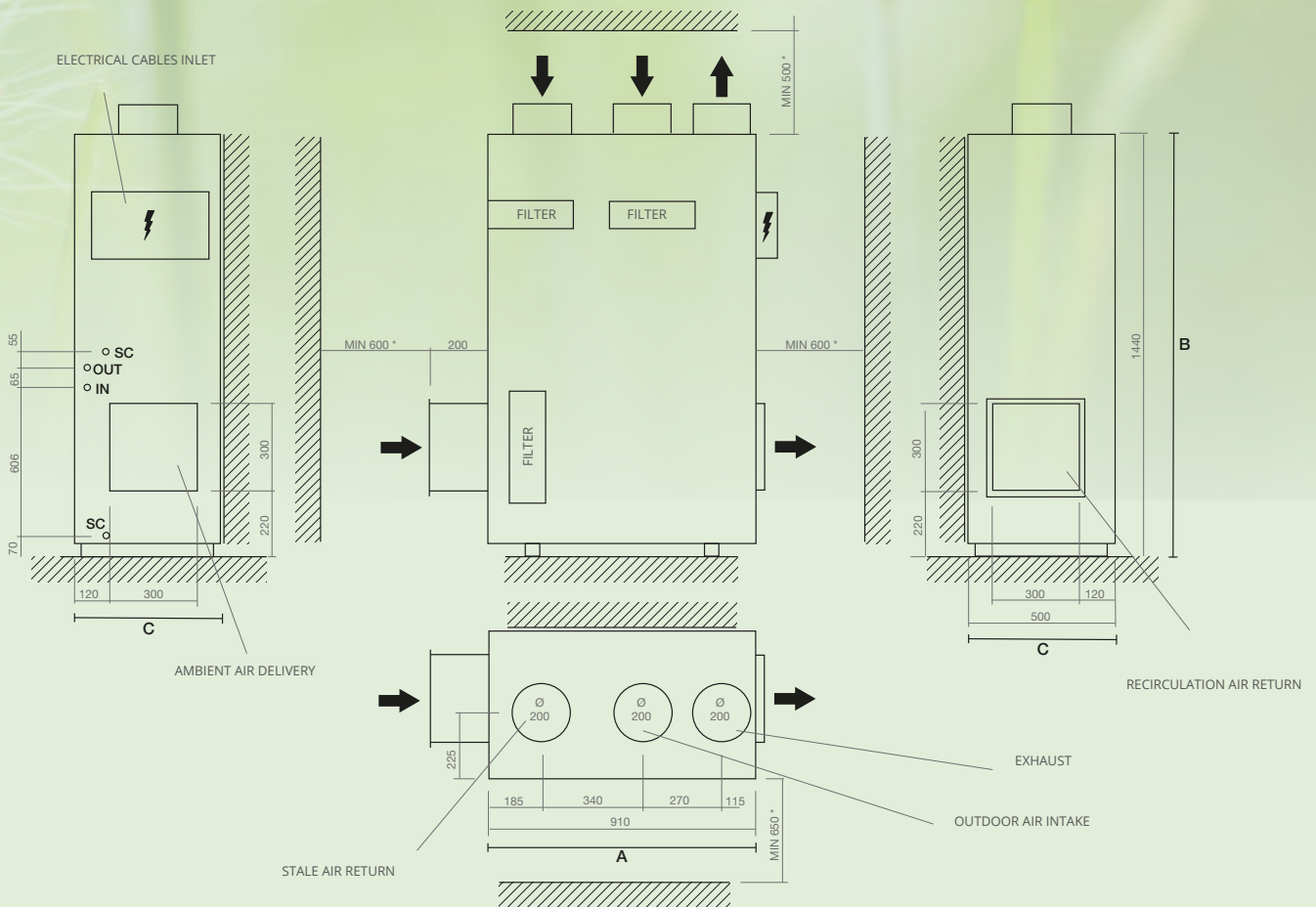

*MINIMUM CLEARANCE VALUES TO OBSERVE FOR MAINTENANCE OF A PRE-INSTALLED WORKING MACHINE



EXAMPLES OF INSTALLATION

ENERGY RATING CLASS

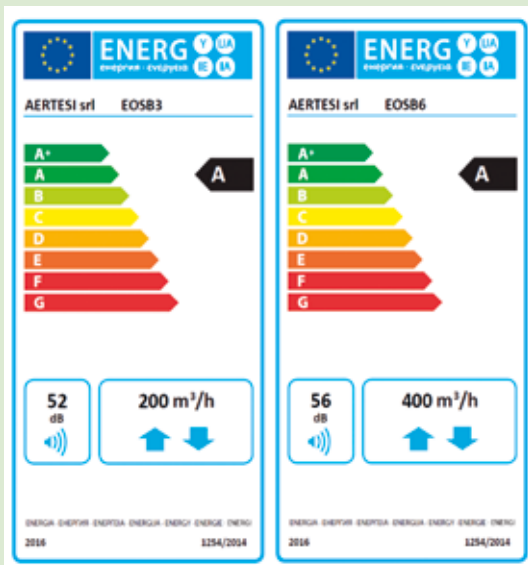

DATA VALID FOR RECOVERY ONLY

Aertes makes certified technologies and devices available to heating system engineers who build and design systems and ducting ensuring demonstrated reduction capacity of the microbial load of different bacterial strains, including virucidal activity against COVID-19.

SANI FAN for sanitising fan-coil internal surfaces with Bioxygen® technology.

BIOXAIR for sanitising aeraulic ducts with Bioxygen® technology.

FILTRASAN fibre suitable for filtering media which retains and removes microorganisms present in the air.

EOS B WATER VERSION WITH HEAT PUMP



CLASS



PASSIVE HOME

WINTER/SUMMER:

- HEATING/COOLING
- COMPLETE AIR TREATMENT WITH V.A.V. SYSTEM (indoor water units)
- FRESH AIR RENEWAL

MID SEASONS:

- RENEWAL ONLY

HSW:

- WITH 3-WAY VALVE

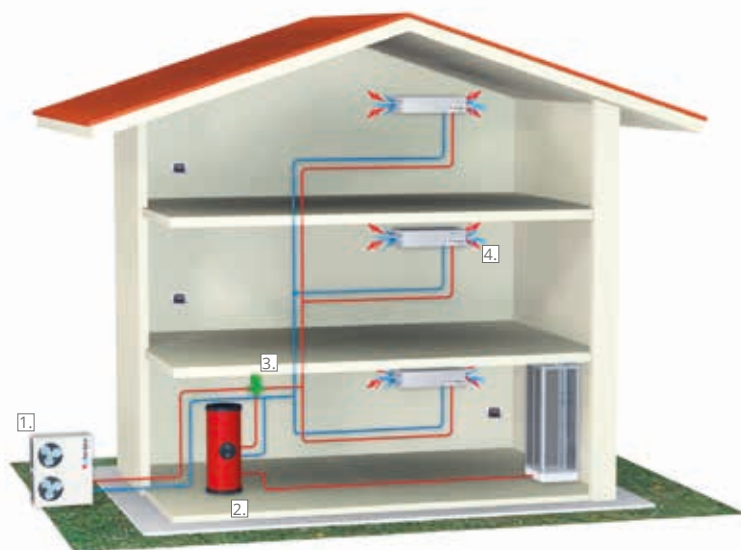

1. HEAT PUMP (NOT SUPPLIED)
2. DOMESTIC WATER ACCUMULATOR (NOT SUPPLIED)
3. 3-WAY DIVERTER VALVE FOR SANITARY WATER PRODUCTION (NOT SUPPLIED)
4. WATER EOS B

EOS B WATER VERSION WITH HEAT PUMP AND RADIANT SYSTEM



CLASS



CLASS

- HEATING:
WITH RADIANT SYSTEM FOR SHORT PERIODS;
- POWERFUL INTEGRATION OF AIR HEATING (start up + high transients) WITH V.A.V. SYSTEM (INDOOR WATER UNITS) + FRESH AIR RENEWAL
- COOLING + DEHUMIDIFICATION: WITH V.A.V. SYSTEM;

MID SEASONS:

- V.A.V. ONLY + FRESH AIR RENEWAL

HOT SANITARY WATER MANAGEMENT WITH 3-WAY VALVE (HSW).

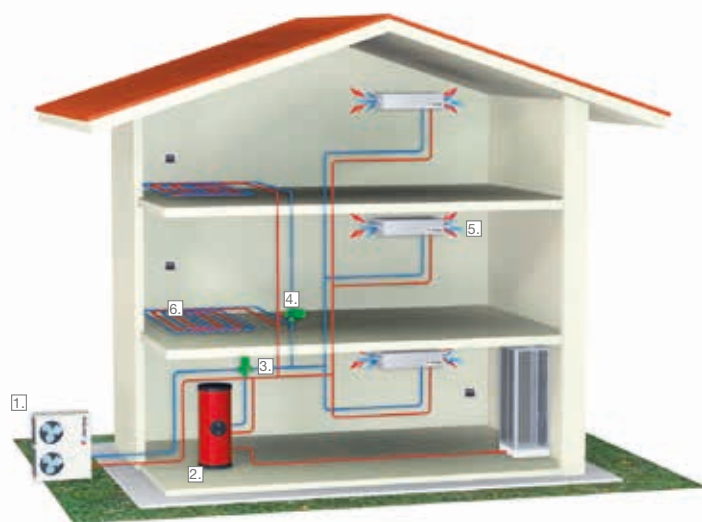

1. HEAT PUMP (NOT SUPPLIED)
2. DOMESTIC WATER ACCUMULATOR (NOT SUPPLIED)
3. 3-WAY DIVERTER VALVE FOR SANITARY WATER PRODUCTION (NOT SUPPLIED)
4. MIXING VALVE
5. WATER EOS B
6. RADIANT SYSTEM (NOT SUPPLIED)



SOLUTIONS

The standard user interface with which EOS B is supplied is the wall-mounted user console allowing users to set: temperature and humidity, CO₂ threshold for fresh air renewal, seasonal control, weekly control for integration renewal and unit status check (alarm).

The user functions can also be managed via the special App from a smartphone or tablet by purchasing the special APP1-EOS modem or from a management system with Modbus communication protocol (supervision program not supplied).



EOS B EC

TECHNICAL DATA - GENERAL

		EOS 3 W	EOS 6 W
Recovery unit rated efficiency in summer (1)	%	85.0	82.3
Recovery unit rated efficiency in winter (2)	%	90.5	88.7
Outside air (rated) flow rate	m ³ /h	200	400
Delivery air (rated) flow rate in renewal only	m ³ /h	200	400
Delivery air (rated) flow rate in recirculation only	m ³ /h	500	1000
Delivery air (rated) flow rate in recirculation only	m ³ /h	500	1000
Sound power (*)	dB(A)	52	56
Power supply	V-Hz	230V-50Hz	
Maximum absorbed current-power	A-W	2.3A – 270W	4.2A – 510W
Weight of horizontal version (H)	kg	50	65
Weight of vertical version (V)	kg	55	70

(*) Radiated from the casing, measured at the reference flow rate at 50Pa (as per EU Regulation 1253/2014)

Performance values are referred to the following conditions:

(1) Ambient air 27°C, 50% RH; outdoor air 35°C, 50% RH

(2) Ambient air 20°C, 50% RH; outdoor air -5°C, 80% RH

TECHNICAL DATA WATER UNIT

		EOS 3 W	EOS 6 W
Total cooling capacity (3)	kW	3.2	6.3
Sensitive cooling capacity (3)	kW	2.4	4.7
Coil water flow rate (3)	l/h	550	1080
Hydraulic circuit pressure drops (3)	kPa	13	12
Thermal power (4)	kW	4.0	8.0
Hydraulic circuit pressure drops (4)	kPa	11	10

Performance values are referred to the following conditions:

Rated air flow (see previous table)

(3) Ambient air 27°C, 47% RH; Inlet-outlet water 7-12°C

(4) Ambient air 20°C, 50% RH; Inlet water 50°C and same flow rate as condition (1)

Aertesi srl
Viale della Tecnica, 6/a
35026 Conselve (PD) ITALY

t. +39.049.9501109
f. +39.049.9500823

www.aertesi.com
info@aertesi.com

